

Drainage channels *Ferrofix Express*

Products

Illustration

Article description

Linear stainless steel channel drains

System 125

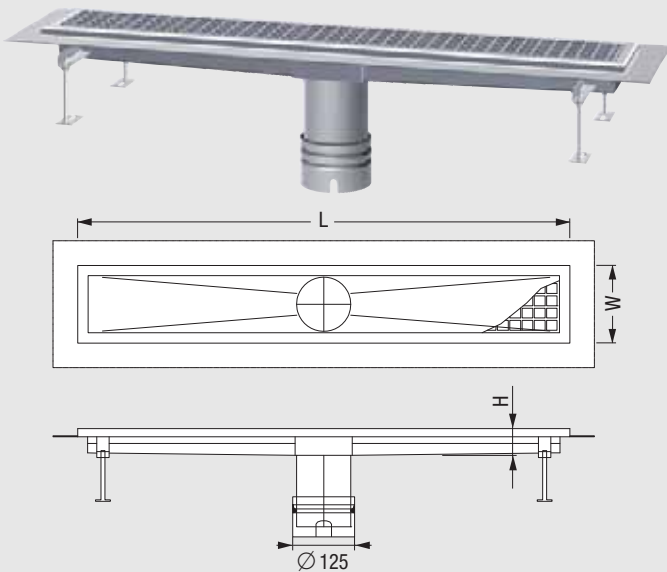

Drainage channels *Ferrofix Express* made of stainless steel

Material thickness 2.0 mm - acid-treated in a pickling bath, visible cover sanded, with longitudinal and transverse slopes, feet for height adjustment, with welded distance grates to secure the covers, **including drain pipes in stainless steel.**

Channel profile for shallow bed seals, with adhesive edge 15 mm deep and 30 mm turned down all-round to the outside, with welded mitre joints.

Linear drainage channels:

Channel lengths (mm) 1042, 1550, 2058 | 1047, 1555, 2063 | 542, 547
Channel widths (mm) 158 | 300 | 158,300

Square drainage channels:

Channel lengths (mm) 500 | 953 | 350, 800, 1000
Channel widths (mm) 500 | 500 | 350, 800, 1000

Material 1.4301 (AISI 304)

Channel profile Adhesive edge for shallow bed seals

With stainless steel cover

Non-slip R11, acid-treated in a pickling bath.

Mesh width: 23 x 23 mm

Load class: L 15 (1.5 ton.)

Square/rectangular stainless steel channel drains

System 125



Sludge trap in stainless steel optional:

- **System 125** Art. # **6125SKH** Construction height 90 mm
Art. # **6125SKN** Construction height 30 mm

On stock :

Dimensions W x L x H	Article #
Linear stainless steel channel drains	
System 125	
158 x 542 x 55 mm	60 15 050
158 x 1042 x 55 mm	60 15 100
158 x 1550 x 58 mm	60 15 150
158 x 2058 x 60 mm	60 15 200
300 x 547 x 58 mm	60 30 050
300 x 1047 x 60 mm	60 30 100
300 x 1555 x 63 mm	60 30 150
300 x 2063 x 65 mm	60 30 200
Square/rectangular stainless steel channel drains	
System 125	
350 x 350 x 60 mm	60 35 035
500 x 500 x 65 mm	60 50 050
500 x 953 x 70 mm	60 50 100
800 x 800 x 60 mm	60 80 080
1000 x 1000 x 65 mm	61 00 100

Matching drain body System 125 optionally as an accessory

Drainage channels *Ferrofix Express*

Accessories



Drain bodies

with removable odour trap

Ecoguss see page 136

Practicus see page 137

Ferrofix see page 192/193

Fire-Kit Fire protection insert

Ø 76 mm,
only for drains with vertical outlet
and odour trap

Art. # **48 100**

Certification no.
Z-19.17-1719

* Certification no.
Z-19.17-1719



Quick-Fit the passage seal

for core drilling, for drain body vertical outlet

1 * with fire protection Art. # **48 990**

(only use in combination with *Fire-Kit* fire protection insert)

2 without fire protection Art. # **48 991**